



24324 Sorrentino Court, Clinton Township, MI 48035 Tel: 586-791-4120 Fax: 586-791-0802

Katech Website: www.katechengines.com

KAT-7635
Katech - Stanadyne DI Goliath
Fuel Pump
Install Instructions





WARNING – FUEL RELATED PRODUCT
Caution should be taken when working with or near fuel related systems.

I. Required for Installation:

- a. 3/8 SAE Quick Disconnect Tool
- b. 17mm Open End Wrench
- c. 5mm Hex Socket
- d. Torque Wrench

II. Procedure:

- a. Disconnect the battery on the vehicle before proceeding
- b. Based on the specific engine/application, remove Intake Manifold or Supercharger per manufacturer's specifications
- c. Remove 3/8 SAE quick disconnect line using 3/8 SAE Quick Disconnect Tool
 - i. Care should be taken with the fuel system to avoid contamination, cap all fuel lines after being disconnected



- d. Remove tee fitting to DI pump high pressure fuel line using 17mm Open End Wrench
 - i. Care should be taken with the fuel system to avoid contamination, cap all fuel lines after being disconnected
 - ii. Per General Motors, all high pressure fuel lines are one time use



- e. Remove electrical connector from the back of OE DI pump
 - i. Verify that the existing connector matches that of the Katech Goliath DI pump
 - ii. If existing connector does not match that of the Katech Goliath DI pump, GMP-12707877 can be purchased to swap the fuel injector subharness to the correct connector
- f. Remove the two M8 bolts from the OE DI Pump
- g. Remove the OE DI pump from the engine
 - i. Care should be taken with the open crankcase, ensuring no debris falls into the engine
 - ii. Verify no lash cap is installed on the DI Lifter. OE engines do not have the lash cap, some aftermarket installs utilize a lash cap, the Katech Goliath DI pump cannot be used with a lash cap
- h. Ensure that the Goliath Fuel Pump is installed with appropriate preload
 - i. Refer to the below image when measuring the pump preload

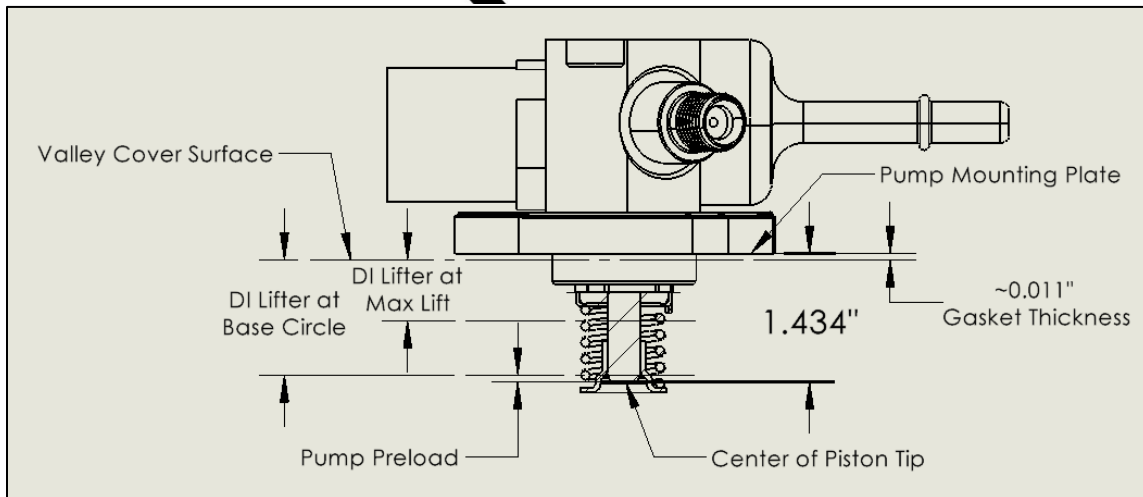

- i. Install the Katech Goliath Fuel Pump, ensuring the pump preload falls within the given specifications
 - i. Minimum Lifter Travel Position: **(0.015" preload from free length)**
 - ii. Maximum Lifter Travel Position: **(0.350" travel from free length)**
- j. If your measurement is within the specs listed above, proceed. If measurement is outside of the range listed above, contact Katech and do not proceed with installation
- k. Install the Katech Goliath DI Pump on the engine
 - i. Torque the two M8 bolts to **18 ft-lbs**



- l. Install tee fitting to DI pump high pressure fuel line using 17mm open end wrench and torque to **22 ft-lbs**
- m. Reinstall 3/8 SAE quick connect line



- i. Verify the line fitting is properly seated and clicked into place on the Katech Goliath DI Pump
- n. Reinstall electrical connector on the back of the Katech Goliath DI pump
- o. Reinstall the Intake Manifold or Supercharger per manufacturer's specifications
- p. Once complete, turn the ignition on with the engine off for 2 seconds then turn off the ignition for 10 seconds
 - i. Repeat this process once more and inspect for leaks

